

INSTALLATION GUIDELINES

for DRYBACK (Glue down LVT)

1. INTRODUCTION

Floorcoverings designed and produced by LG HAUSYS (LGH), as DRYBACK, is interior floorcovering products for a glue down application compliant with the regional rules.

2. PRIOR TO INSTALLATION

Storage

DRYBACK must be stored on a flat surface in a dry and ventilated area. Do not store floorcovering in very cold (less than 0°C) or very warm (more than 35°C) or humid area.¹

Inspection:

Despite the care and rigor during production, a visual inspection of the materials before installation is recommended, such as, batch number, reference, colour, design, and for differences or defects, to prevent from installation of false materials.²

In case any visual faults are detected on materials, do not install the faulty products and contact your local dealer, to obtain information about the way of proceeding.

LGH recommend to install products in with the same batch/lot number only in the same area.³

In any case, store the boxes laying down flat and do not store standing up or leaning the boxes on the wall.⁴

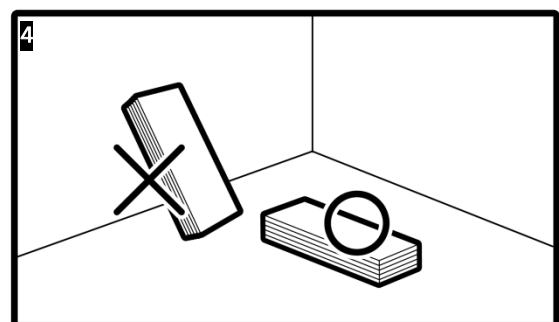
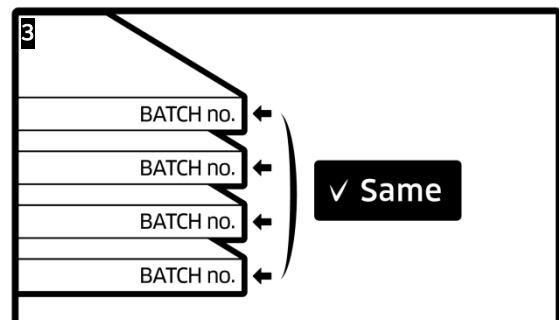
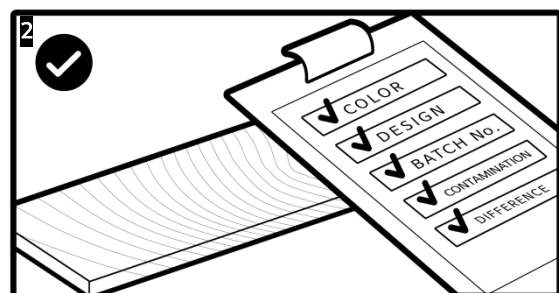
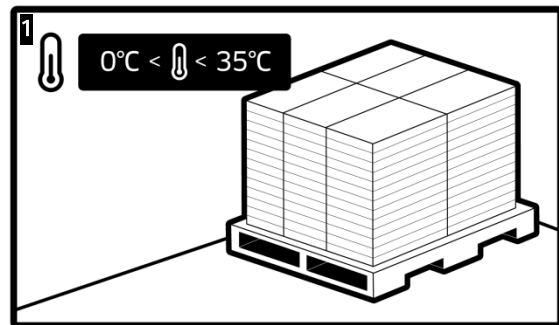

Acclimation:

DRYBACK needs to follow proper acclimation process. LGH recommends to leave the materials at the installation site at least for one day at room temperature (18°C~29°C) to obtain perfection in installation. Similar temperature and time are required for Adhesives as well.⁵

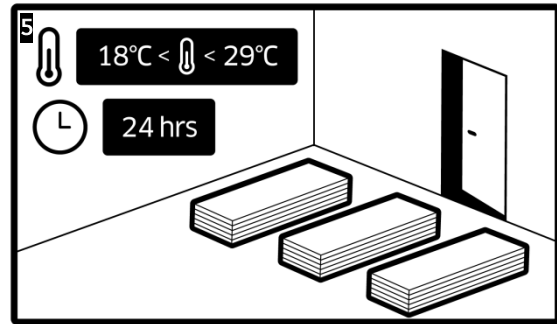

3. SUITABLE SUBFLOORS

DRYBACK installation requirements must be compliant with regional standards or norms. Subfloor analysis is under installer responsibility.

LGH cannot be considered as responsible for damaged on floorcovering due to not suitable subfloor.

Any floorcoverings previously installed must be removed completely.⁶

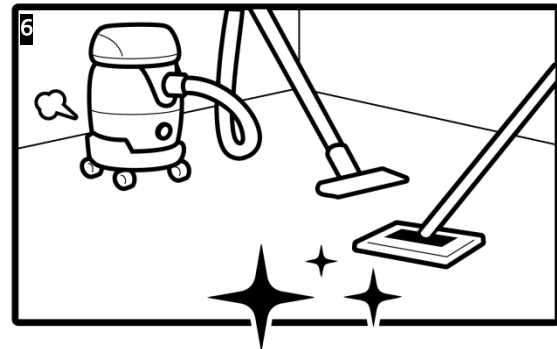

Then the floor must be cleaned by vacuum cleaner and damp mop to remove dust, contamination, and/or foreign substances that might disturb proper installation.⁷

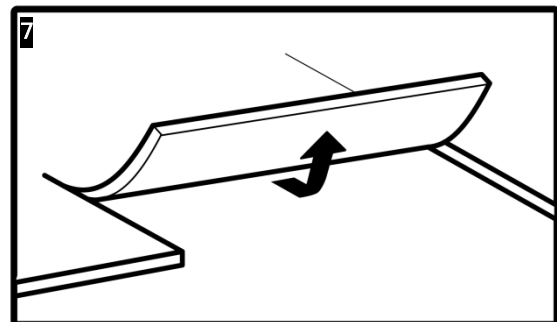

The installation site needs to be cured sufficiently by operating a heater before installation.

Then humidity needs to be checked at five random spots, and the average value should be less than 5% CCM (and less than 75% RH).⁸

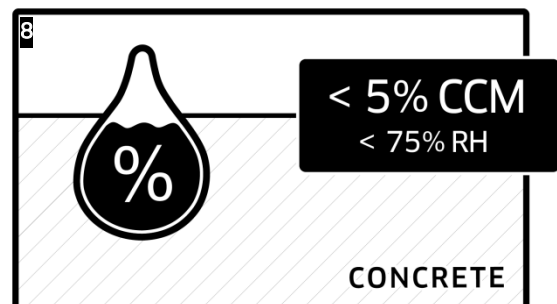

Regional requirements could be different, so please check the local or national requirements before installation.

4. ADHESIVES SELECTION

LGH, recommend usage of respectful adhesives for health and safety rules for workers and which are eco-friendly. Solvent base adhesives are prohibited. Using these adhesives can have negative effects on the floorcovering behaviour. LGH cannot be considered as responsible for damaged on floorcovering due to not suitable adhesive use. LGH, recommends usage of acrylic adhesive and specifically for DRYBACK floorcoverings, LVT acrylic adhesives.

Please contact the LGH Technical Department to obtain information about suitable adhesives, or recommended manufacturers. Adhesives usage must be done in accordance with manufacturer recommendation.

5. INSTALLATION

DRYBACK installation must follow the regional requirements.

- Draw center lines across the installation site, so that the entire site is divided into Quadrant. Then determine which of the four areas to begin with and begin placing products from the center.
- Most common installation methods based on the dimension of the products are as follows:
 - .1/3 step installation for wood plank⁹
 - .1/2 step installation for rectangle tile¹⁰
 - .Ceramic tile installation for square tile¹¹
- The amount of applied adhesive may vary depending on the floor condition, but usually 0.09~0.12kg is required per sqm.
- Lay the planks or tiles, into the tacked-off adhesive, in order to transfer the adhesive fully onto the backing.
- Cut the planks or tiles, free of tension, against the wall or existing skirtings
- To ensure full contact with adhesive, immediately press every plank or tile with a rubbing block or hand roller.¹²

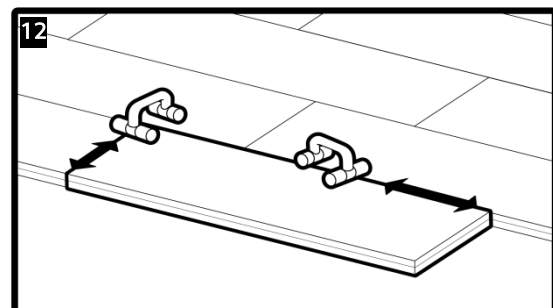
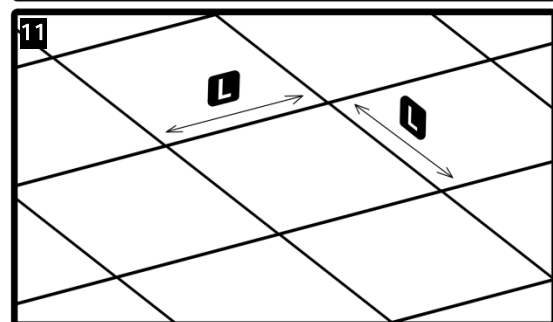
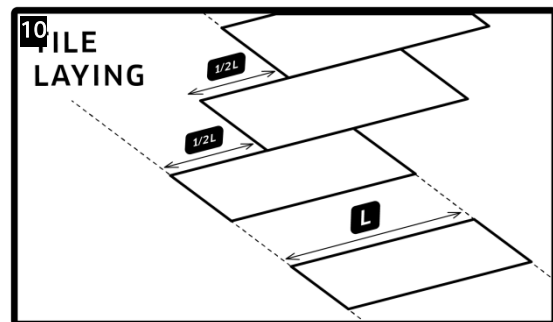
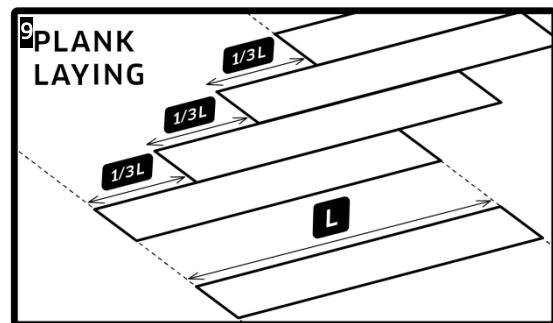

- Immediately roll each section with a (minimum) 50kg flooring roller. Roll several times, in different direction, during the adhesive working time.¹³
- Clean adhesives stains with a damp cloth.

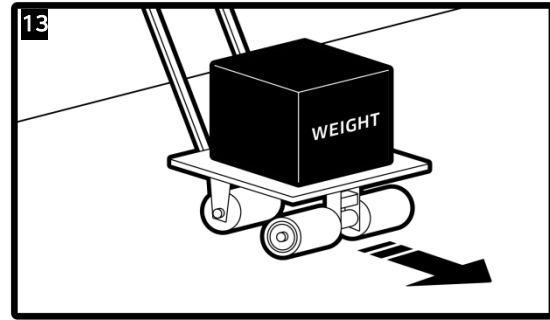

6. Protection and open to traffic

DRYBACK needs to be protected from heavy traffic for 72 hours to have a perfect adhesive stabilisation time. Light Pedestrian traffic is allowed. All other operation as furniture installation need to be postponed for the next 72 hours.¹⁴

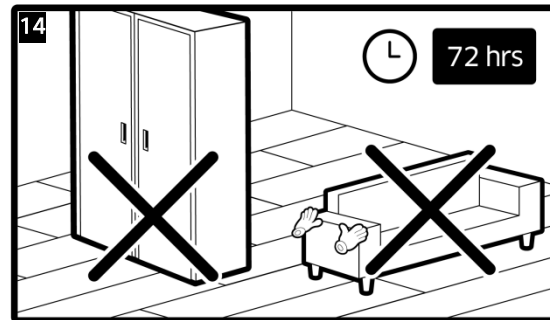

7. First Cleaning after installation

Prior to open the area to the normal traffic, LGH recommends to clean the surface using vacuum cleaner.¹⁵

To keep DRYBACK in perfect condition, LGH recommends regular cleaning and maintenance with the right cleaning process.

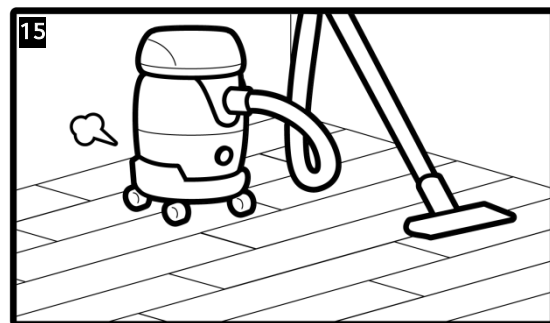

During furniture installation or movements, LGH recommend to protect the floorcovering and equipped the furniture legs with adapted pad.

The product needs to be protected for long time exposure of direct sunlight. Windows and Glass doors need to be covered properly to protect the nearby floorcoverings.¹⁶

If the products are installed in front of exterior access doors or windows, an entrance mat needs to be utilized.

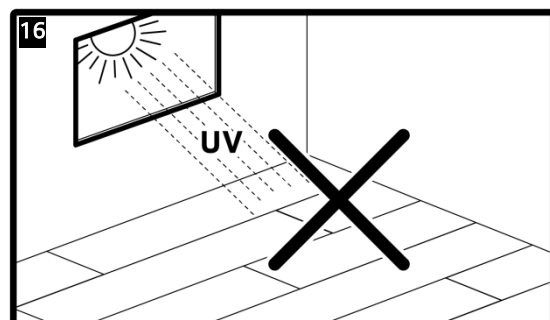

For additional information or advices about cleaning and protection, please refer to LGH cleaning guidelines.